

HDM 36

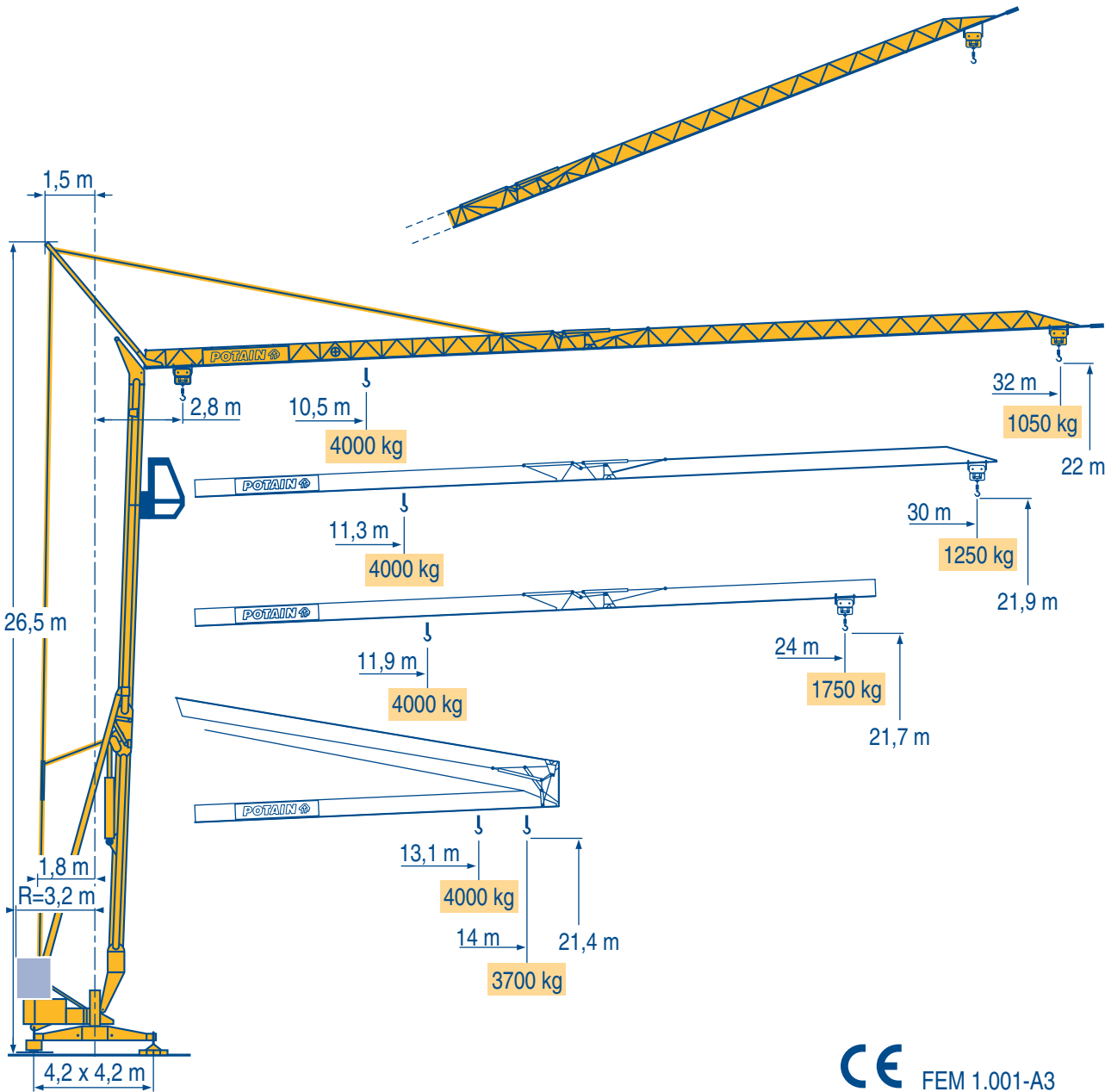

Igo
HD
HDM



HDT



GTMR



CITY CRANE



TOPKIT MD
MAXI MD



MAXI TOPKIT



Topless MDT



MR



CE FEM 1.001-A3



POTAIN 

Courbes de charges
Lastkurven



Load diagrams
Curvas de cargas



Curve di carico
负荷曲线

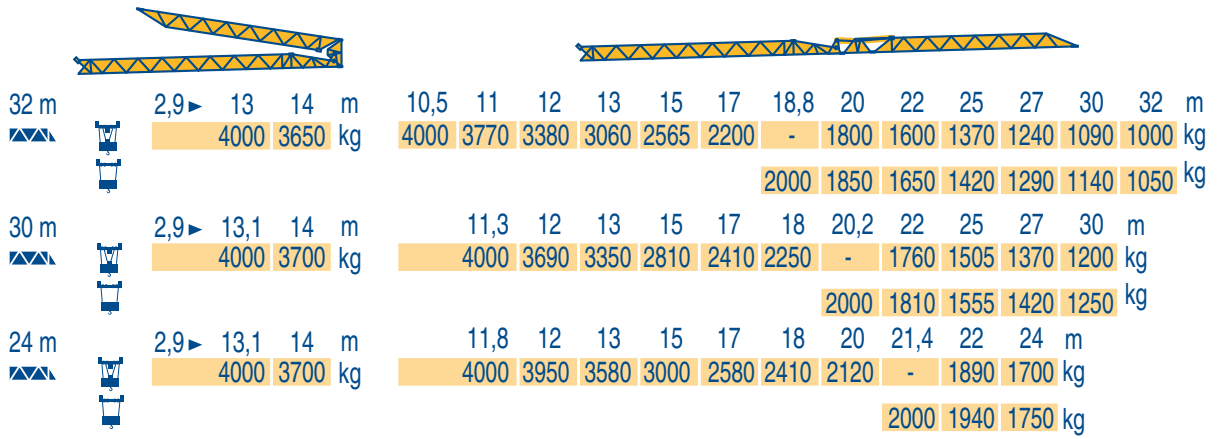

LTP 1

Flèche relevée
Ausleger in Steilstellung



Luffing jib
Flecha izada



Braccio impennato
起升吊臂

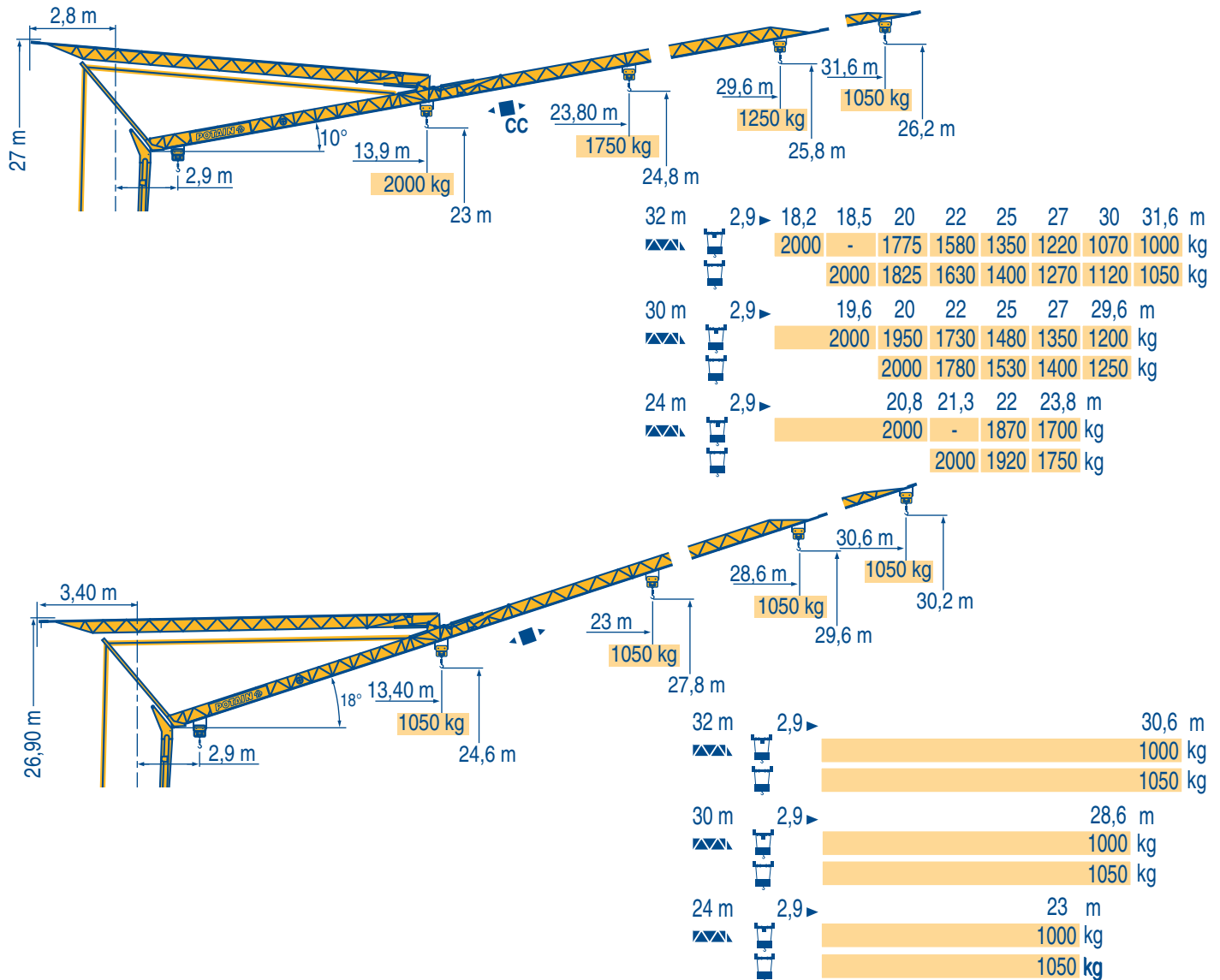

LTP 1

Chariot distributeur
Chariot distributeur
et courbes de charges

Traversing trolley
Traversing trolley
and load diagrams

Carrellino distributore
Carrellino distributore
e curve di carico



Verfahrbare laufkatze
Verfahrbare laufkatze
und lastkurven

Carro distribuidor
Carro distribuidor
y curvas de cargas

变幅小车
变副滑车和
负荷曲线



Réactions
Eckdrücke



Reactions
Reacciones



Reazioni
反力

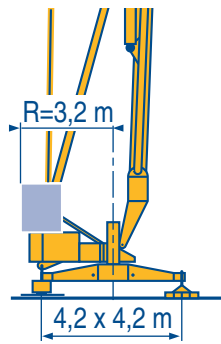

F1 ● 21,2 t ■ 13,9 t

👤 11,3 t

LTP 1

● Réactions en service
■ Réactions hors service
👤 A vide sans lest (ni train de transport) avec flèche et hauteur maximum



Reactions in service
Reactions out of service
Without load, ballast (or transport axes), with maximum jib and maximum height.



Reazioni in servizio
Reazioni fuori servizio
A vuoto, senza zavorra (ne assali di trasporto) con braccio massimo e altezza massima



● Reaktionskräfte in Betrieb
■ Reaktionskräfte außer Betrieb
👤 Ohne Last, Ballast (und Transportachse), mit Maximalausleger und Maximalhöhe.



Reacciones en servicio
Reacciones fuera de servicio
Sin carga, sin lastre, (ni tren de transporte), flecha y altura máxima.



工作状态下的反应
非工作状态下的反应
空载无压重也无运输车
有吊臂和最大高度



Mécanismes
Antriebe



Mechanisms
Mecanismos



Meccanismi
机构



										ch - PS hp	kW	
▲	15 LVF 10	m/min	5	27	43	53	2,5	13,5	21,5	26,5	15	11
		kg	2000	2000	1250	1050	4000	4000	2500	2000		
▼	15 RPC 10 A	m/min	9	27	54		4,5	13,5	27		15	11
		kg	2000	2000	1050		4000	4000	2000			
◀ ▶	3 D2 V5/2	m/min	21 - 42								2,7	2
🔄	RVF 2 30	tr/min U/min rpm	0 → 0,2 → 0,8								1,5	1,1

CEI 38	IEC 38	kVA	
400 V (+6% -10%) 50 Hz		20 kVA	84/534 - 87/405

LTP 2

▲ Leverage
◀ ▶ Distribution
🔄 Orientation
👤 Conforme aux directives CEE 84/534 et 87/405 sur le niveau acoustique



Hoisting
Trolleying
Slewing
In compliance with the EEC 84/534 and 87/405 Instructions on noise level



Sollevamento
Distribuzione
Rotazione
Conforme alle direttive CEE 84/534 e 87/405 sul livello acustico



▲ Heben
◀ ▶ Katzfahren
🔄 Schwenken
👤 Gemäss EWG-Richtlinien 84/534 und 87/405 für den Schall-Leistungspegel



Elevación
Distribución
Orientación
Conforme con las directivas CEE 84/534 y 87/405 sobre el nivel acustico



起升
变幅
回转
符合 CEE 84/534 - CEE 87/405 声响度规定



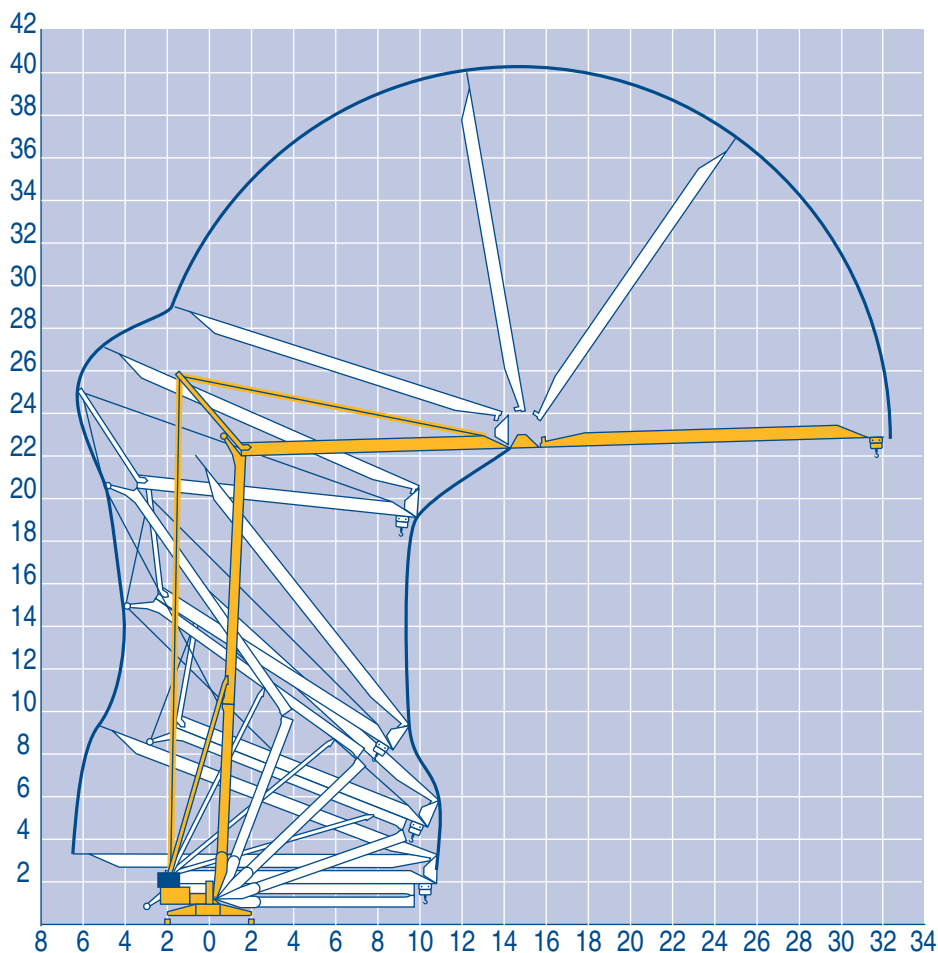

LTP 1

Version semi-portée lestée

F Tractor towed version
with ballast

GB Versione semi rimorchio
con zavorra

I

Ausführung als Sattelaufleger
mit ballast

D Version en semi-remorque
con lastre

E 带压重半拖挂

C

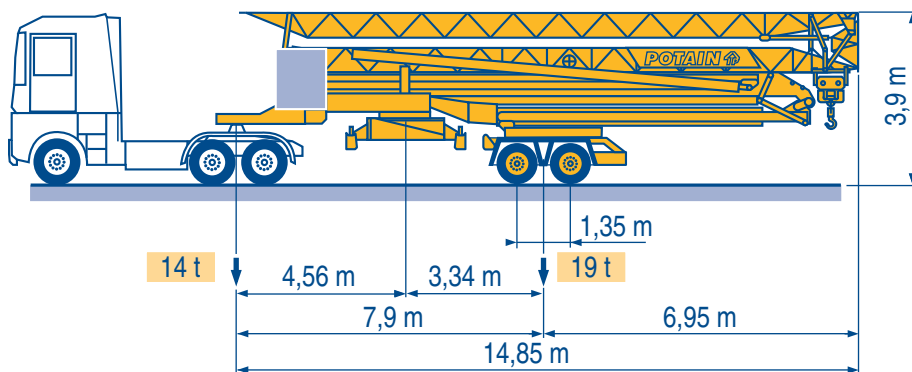

SL121/S215M

SL122/J215M

LTP 1



18.Rue de Charbonnières, B.P. 173
F-69132 ECULLY Cedex

Tél. (33)04.72.18.20.20
Fax (33)04.72.18.20.00
http://www.potain.com
E-mail : mkt@potain.fr

HDM 36

Copyright.Reproduction interdite © POTAIN 2000

Deutschland

POTAIN GmbH

Tel : 06.105.704.0

Italia

POTAIN S.p.A.

Tel : 0.331.49.33.11

Singapore

POTAIN PTE LTD

Tel : (00.65) 227.1550