

# POTAIN

## MC 58

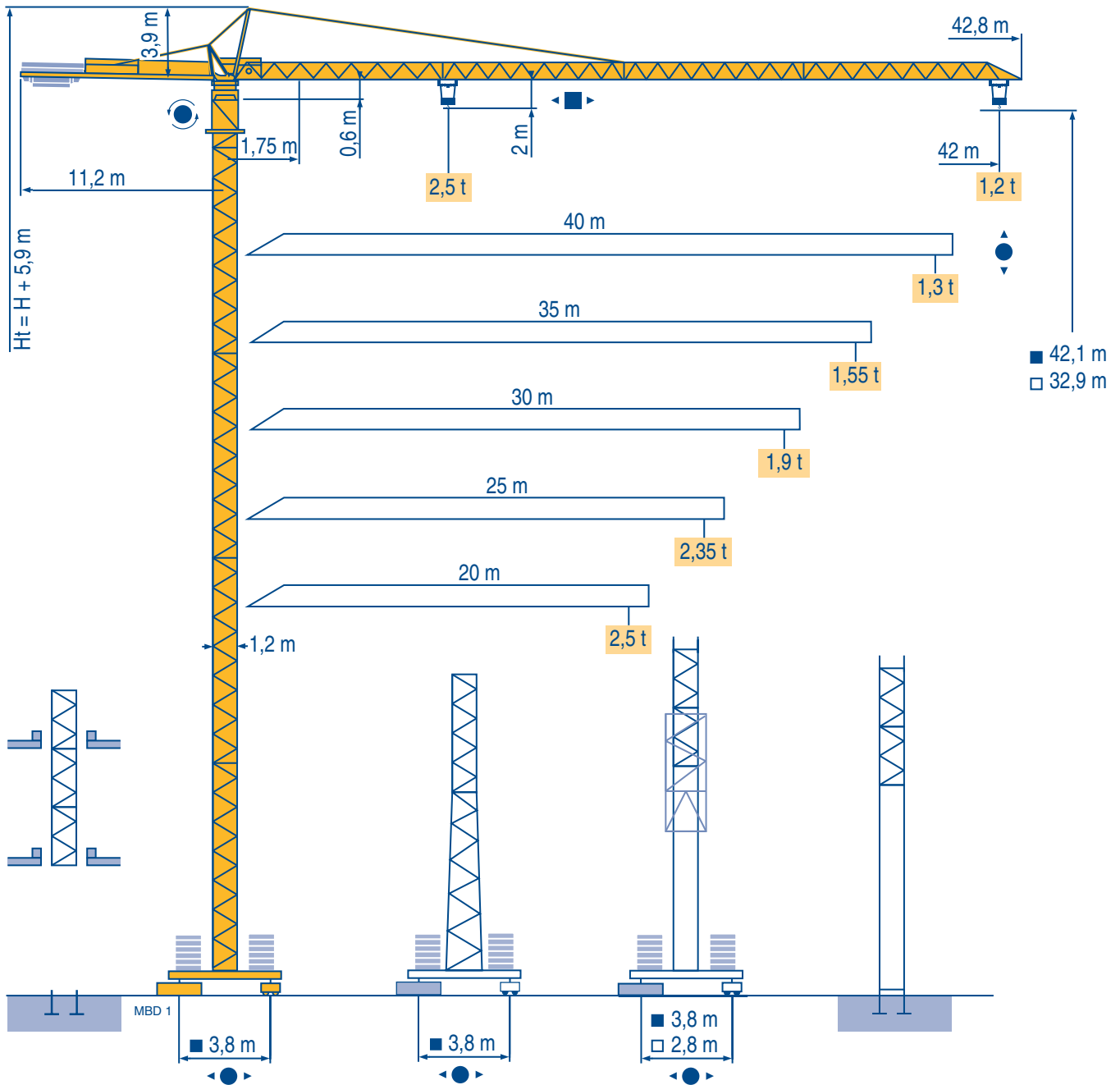

### CITY CRANE

CE FEM 1.001-A3

 **Manitowoc**  
Crane Group

Above. Beyond. Everywhere.™

Mat / Réactions  $\square$  1,2 m

Maste /  
Eckdrücke  
Masts /  
Reactions  
Mástil /  
Reacciones  
Torre / Reazioni  
Tramo /  
Reacções

20 m  $\Rightarrow$  42 m

MBD 3

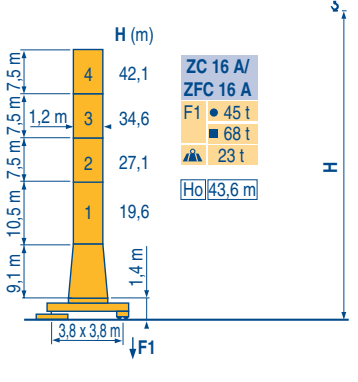
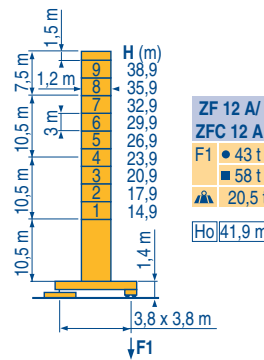
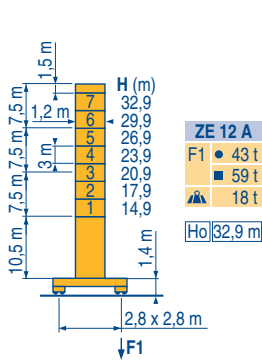
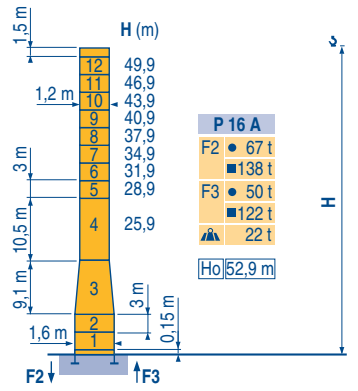
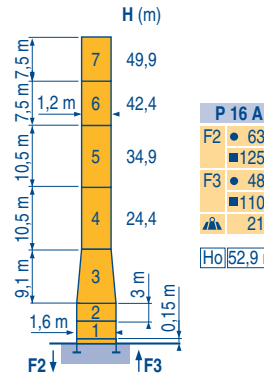
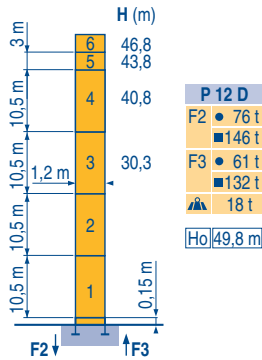
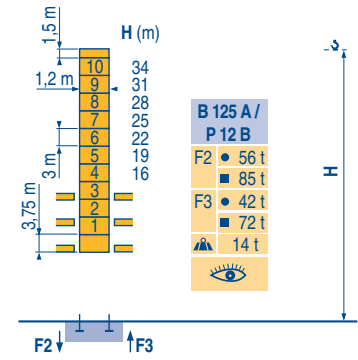
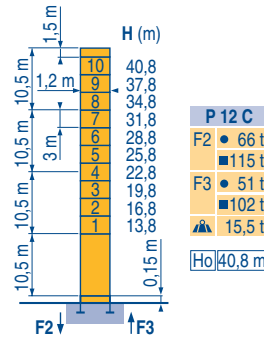
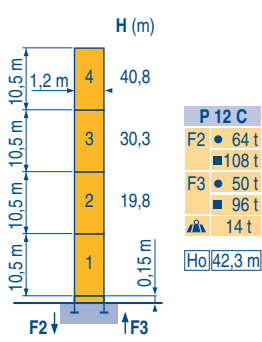

ZE - ZF - ZC - ZFC



CITY CRANE  
MC 58



F	D	GB	E	I	P
●	●	●	●	●	●
■	■	■	■	■	■
▲	▲	▲	▲	▲	▲
Reações en service	Reaktionskräfte in Betrieb	Reactions in service	Reacciones en servicio	Reazioni in servizio	Reacções em serviço
Reações hors service	Reaktionskräfte außer Betrieb	Reactions out of service	Reacciones fuera de servicio	Reazioni fuori servizio	Reacções fora de serviço
A vide sans lest (ni train de transport) avec flèche et hauteur maximum.	Ohne Last, Ballast (und Transportachse), mit Maximalausleger und Maximalhöhe.	Without load, ballast (or transport axles), with maximum jib and maximum height.	Sin carga, sin lastre, (ni tren de transporte), flecha y altura máxima.	A vuoto, senza zavorra (ne assali di trasporto) con braccio massimo e altezza massima.	Sem carga (nem trem de transporte)- sem lastro com lança e altura máximas.
Ho	H	H	H	H	H
sans cabine	Ohne Fahrerhaus	without cab	sin cabina	senza cabina	sem cabine

Courbes de charges  
Lastkurven  
Load diagrams  
Curvas de cargas  
Curve di carico  
Curva de cargas

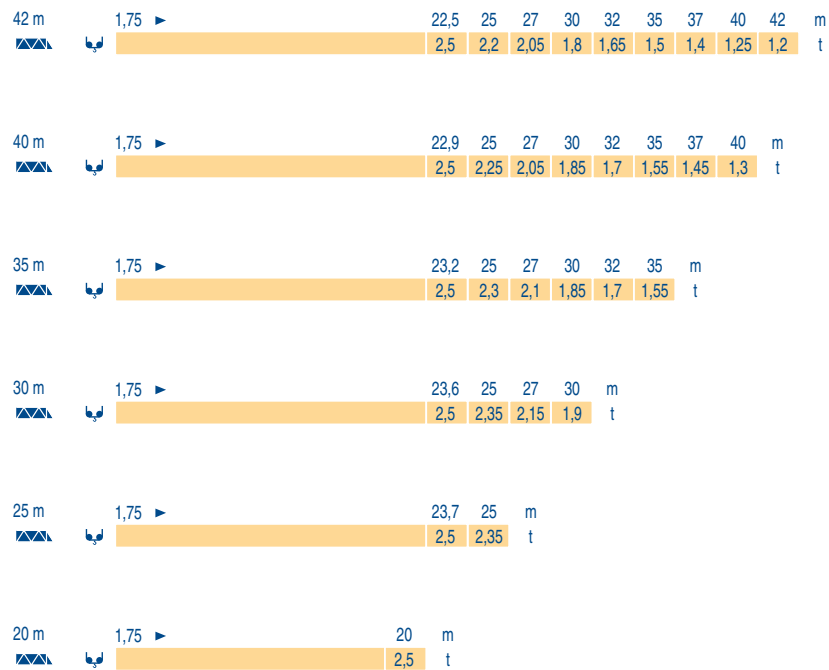

MBD 1

Télescopage sur dalles  
Kletterkrane im Gebäude  
Climbing crane  
Telescopage gruas trepadoras  
Gru in cavedio  
Telescopagem sobre lages

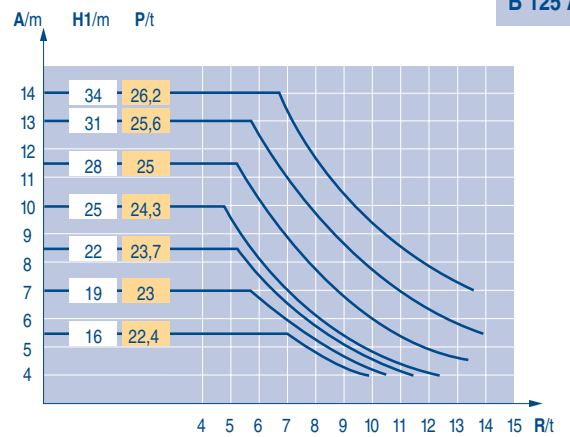
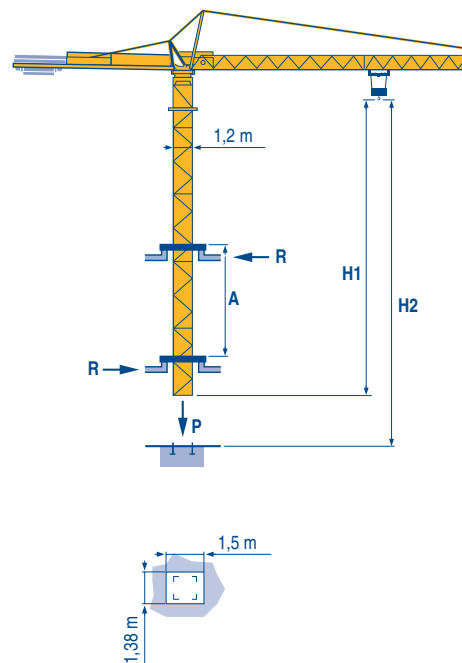

B 125 A

MBD 1

CITY CRANE  
MC 58

POTAIN

	F	D	GB	E	I	P
<b>A</b>	Distance entre cadres	Abstand zwischen den Rahmen	Distance between collars	Distancia entra marcos	Distanza fra i telai	Distância entre quadros
<b>H1</b>	Hauteur grue	Kranhöhe	Crane height	Altura grúa	Altezza gru	Altura da grua
<b>P</b>	Poids de la grue(en service)	Krangewicht (in Betrieb)	Crane weight (in service)	Peso de la grúa (en servicio)	Peso della gru (in servizio)	Peso da grua (em serviço)
<b>R</b>	Réaction horizontale	Horizontalkräfte	Horizontal reaction	Reaccion horizontal	Reazione orizzontale	Reacção horizontal
	Voir télescopage sur dalles	Siehe Kletterkrane im Gebäude	See climbing crane	Vea grua trepadora	Consultare gru in cavedio	Ver telescopagem sobre lages

Mécanismes  
Antriebe  
Mechanisms  
Mecanismos  
Meccanismi  
Mecanismos

MBD 2

					ch - PS hp	kW			
	15 PC 13 AC-1	m/min	7,1	21	42	15	11	130 m	
		t	2,5	2,5	1,3				
	25 PC 13 AC-1	m/min	7,9	31,5	63	25	18		
		t	2,5	2,5	1,3				
20 LVF 13	m/min	5 →	31 →	57 →	75	20	15	230 m	
	t	2,5	2,5	1,3	0,65				
	3 D2 V5	m/min	21 - 42			3	2,2		
	RCV 40	tr/min U/min rpm	0 → 0,8			6	4,5		
	ZE - ZF 	TVD 324	m/min	26			2 x 4	2 x 2,9	
	ZC - ZFC 	RT 224	m/min	25			2 x 4	2 x 2,9	
CEI 38		kVA							
400 V (+6% -10%) 50 Hz		15 PC : 25 kVA 25 PC : 35 kVA 20 LVF : 30 kVA			2000/14				

	F	D	GB	E	I	P
	Levage	Heben	Hoisting	Elevación	Sollevamento	Elevação
	Distribution	Katzfahren	Trolleying	Distribución	Ditribuzione	Distribuição
	Orientation	Schwenken	Slewing	Orientación	Rotazione	Rotação
	Translation	Kranfahren	Travelling	Traslación	Traslazione	Tranlação
	Conforme aux directives CEE sur le niveau acoustique	Gemäss EWG-Richtlinien für den Schall-Leistungspegel	In compliance with the EEC Instructions on noise level	Conforme con las directivas CEE sobre el nivel acustico	Conforme alle direttive CEE sul livello acustico	Conforme as directivas CEE sobre o nível acústico

	Document commercial non contractuel. Pour toute information technique se référer à la notice correspondante	Unverbindliches Vertriebsdokument. Für technische Informationen, siehe die entsprechenden Anweisungen.	This commercial document is not legally binding. For any technical information, please refer to the corresponding instructions.	Documento comercial no contractual. Para cualquier información técnica, ver la noticia correspondiente.	Documento commerciale non vincolante, per tutte le informazioni tecniche fare riferimento al catalogo istruzioni	Documento comercial não contratual. Para qualquer informação técnica complementar consultar as respectivas instruções
--	---	--	---	---	--	---

**Manitowoc**  
Crane CARE

**POTAIN**

Manitowoc Crane Group



**Americas**  
Tel: +1 920 683 6322  
Tel: +1 717 597 8121

**Europe - Middle East - Africa**  
Tel: +(33) 4 72 81 50 00  
Tel: +(44) 191 565 6281

**Asia - Pacific**  
Tel: +(65) 6861 7133  
Fax: +(65) 6862 4142

www.manitowoccrane.com

18, rue de Charbonnières - B.P.173  
69132 ECULLY Cedex - France

Tél. : (33) 4 72 18 20 20  
Fax. : (33) 4 72 18 20 00  
www.manitowoccrane.com www.potain.com

**CITY CRANE MC 58**  
Réf. 2004 12 MBD 4

Copyright.Reproduction interdite © POTAIN 2004

Réalisation Sedoc